

# Electrical Vehicle with Reduced Voltage Induction Motor Drive Using MLI

<sup>1</sup>Y.SANTHA KUMARI, <sup>2</sup>POMYA

<sup>1</sup>(M-tech Student Scholar) Department of Electrical & Electronics Engineering, Anurag Engineering College, Kodad; Nalgonda (Dt); T.S, India.

<sup>2</sup>(Assistant Professor) Department of Electrical & Electronics Engineering, Anurag Engineering College, Kodad; Nalgonda (Dt); T.S, India

---

**Abstract:** This paper presents the design, analysis and implementation of a proposed combined three phase induction motor and its drive system to meet the demand of low-voltage electrical system for hybrid and electric cars, avoiding the high voltage human risks, expensive and complex requirements of the higher voltage insulation and power electronic devices. Development of Electric Vehicles (EVs) and Hybrid Electric Vehicles (HEVs) will offer many new opportunities and challenges to the power electronics industry, especially in the development of the main traction motor drive. Cascade H-bridge (CHB) multilevel inverter with minimum output harmonics for electric/hybrid electric vehicle applications is proposed in this paper. Switching angles of switch devices are determined by selective harmonic elimination technique. So, the effect of low order harmonics are reduced, as a result the efficiency of system has improved. Moreover, the number of DC voltage sources that used in the proposed inverter is less than conventional multilevel inverters that leads to reduce the inverter costs A conventional 220V 3-ph induction motor has been rewound in order to get the required 48V 3-ph motor. The simulation results are obtained using MATLAB/SIMULINK software.

**Keywords:** Electrical Vehicle Reduced Voltage, Induction Motor, Drive Using MLI.

---

## I. INTRODUCTION

Electric vehicle technology is seen by many countries as a key component in the effort to reduce harmful greenhouse gas emissions, while also reducing the dependence on imported petroleum for use by the transport sector. As a result, many automotive manufacturers have begun to place increased emphasis on the development of various types of electric vehicles (EVs). These include battery electric vehicles, which operate purely from battery power, and plug-in hybrid electric vehicles, which operate on power from a combination of an on-board battery and a combustion engine. The batteries for both types of technology can be recharged from external energy sources, e.g. an electricity network. The government in the Republic of Ireland has set out targets for reducing overall greenhouse gas emissions as well as specific targets of 10% of the Irish transport fleet to be fully electric by 2020 [1].

Of all the components in an electric drive conversion, the motor is probably the most important. The motor has the most influence on the performance (speed, acceleration, efficiency) of the converted vehicle. Also, the motor influences the selection of other major components of the vehicle (controller, batteries, and indirectly the charger and DC/DC converter). The motor is a primary factor in the cost of the conversion. There are several motor types and many sizes (power) and form factors (physical shapes) of these motor types. the choice of motor types is reduced to just two types: series wound DC brushed machines and three-phase AC induction machines. The advantages and disadvantages for these two motor types are listed in Table 1

Table 1: Series DC Brushed Machine to 3-phase AC Induction Machine Comparison

| Series DC: Advantage                              | Importance to application  |
|---|--|
| 1. Commonly available                             | Multiple vendors   |
| 2. High peak torque for a given hp size           | Faster acceleration of vehicle.  |
| 3. Available in lower voltage windings            | Less batteries in series required.   |
| Series DC: Disadvantage                           |  |
| 1. Brushes (arching, wear, carbon dust)           | Possible to ignite flammable environments, radio interference, increased maintenance, electrical shock |
| 2. "Open" motor                                   | Susceptible to damage from water spray   |
| 3. Generally lower maximum speed                  | Uses a smaller gear ratio so tends to negate advantage #2  |
| Induction AC: Advantage                           |  |
| 1. "Brushless" motor                              | More reliable, virtually maintenance free, no arching, no carbon dust.                                 |
| 2. Sealed motors                                  | Water or cleaning spray not a problem.   |
| 3. Generally higher efficiency                    | Longer run time on a given battery charge.   |
| 4. Most AC controllers offer regenerative braking | Returns some energy for slightly longer driving range.   |
| Induction AC: Disadvantages                       |  |
| 1. Generally 240V or higher voltage               | Requires more batteries in series.   |
| 2. Controller more expensive than DC              | More expensive conversion.   |

The overwhelming disadvantage to DC brushed machines (both series wound and other types) are the brushes themselves. Brushes ride on the commutator of the motor's armature (the part of the motor that turns) and form a rotary switch that switches high currents to various sections of the armature coils. The mechanical nature of this rotary switching of high power produces considerable electrical arcing and also mechanical wear of the carbon brushes and the copper segments of the commutator. This arcing can ignite flammable vapors if they are present around the motor. Although this condition is generally unlikely, the possibility of such ignition usually excludes brushed motors from commercially manufactured vehicles. In contrast, an AC induction motor, which has no brushes, completely eliminates this risk.

Besides the ignition risk, brushes produce electrical noise (EMI/RFI) that can interfere with cell phones, computers, and other electronics. Because brushes are subject to mechanical wear they should be checked annually (increased maintenance) and may have to be replaced every few years. Carbon dust is produced as they wear. The dust is conductive and can cause unintended connections between high voltage and the vehicle chassis. Such connection paths can electrically shock those who service the vehicle.

An induction AC motor avoids these problems. They are generally of higher efficiency; virtually maintenance-free operation, sealed or splash resistant, and the controllers generally provide regenerative braking. But, the controllers (each motor type requires a specific type of controller) are more complicated and more expensive for AC.

So AC motor systems are typically more expensive than comparable DC brushed motor systems. Most AC induction motors are used in industrial applications. They are designed to operate at 240 volts AC or higher. As a result, using AC motors in electric vehicles generally requires higher voltage battery packs, thus a greater quantity of batteries to obtain the higher voltage. The greater number of batteries also adds cost in more battery cables and a higher voltage charger than for a lower voltage system. Industrial motors can be rewound to operate on lower voltages, but that would be a "custom" motor and more expensive than a standard motor. The cost of the custom rewinding will be comparable to the cost of extra batteries. Higher voltage AC motors run faster than lower voltage motors (or DC motors) and are more efficient. Rewinding for lower voltage operation will increase the electrical current requirements, which means thicker cables and also a drop in efficiency.

## II. DEVELOPMENT OF ELECTRIC VEHICLE TECHNOLOGIES

The developed trends of various electric vehicles with respect to different papers published on various topics can be categorized as depicted in figure 1 and summarized as

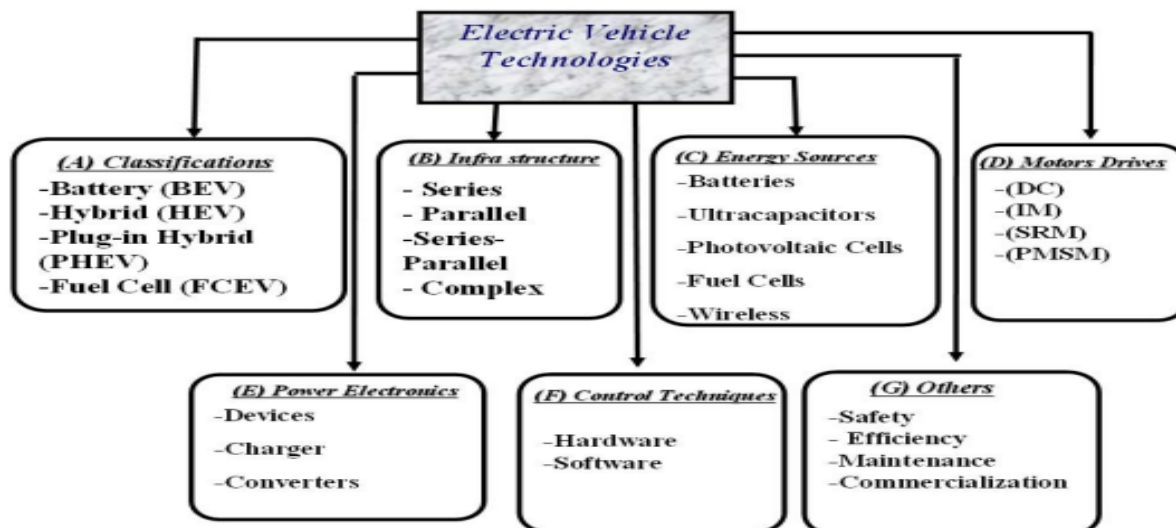

Fig.1. Developed trends of various electric vehicles

### A. Classifications

The critical issue of BEV is the battery. Therefore, BEV is mainly suitable for small EV for short range and low speed community transportation. HEV can meet consumers' need and has many added values, but cost is the major issue. FCEV has long term potential for future main stream vehicles; however the technology is still in development stage while cost and refueling are the major concerns [1] and [2].

### B. Infrastructure

The key feature of the series hybrid is to couple the electric power from the ICE/generator and the battery together to supply the electric motor to propel the wheels, whereas the key feature of the parallel hybrid is to couple the mechanical power from the ICE and the electric motor to propel the wheels. The series-parallel hybrid is a direct combination of both. On top of the series-parallel hybrid operation, the complex hybrid can offer additional and versatile operating modes [1], [3] and [5].

### C. Energy Source

The EV energy source has been identified to be the major obstacle of EV commercialization, with the following development criteria: - High specific energy (kWh/kg) and energy density (kWh/L); High specific power (kW/kg) and power density (kW/L); Fast-charging and deep-discharging capabilities; Long cycle and service lives; Self-discharging rate and high-charging efficiency; Safety and cost effectiveness; Maintenance-free; and Environmentally sound and recyclable. A single source of energy cannot meet the energy requirements for an electric vehicle. For the hybridization of two energy sources, one is selected for high specific energy while the other for high specific power [1], [3] and [4].

### D. Motor Drives

Induction motor (IM) and permanent magnet (PM) motor drives are highly dominant, whereas those on direct current (DC) motor drives are dropping while those on switched reluctance (SR) motor drives are still in a crawling stage. In terms of efficiency, the most efficient motor drives are the permanent magnet brushless motor. Next come the induction and the switched reluctance motor drives which have almost identical efficiency and the least efficient are the DC motors. In terms of the maturity of the technology for being used in propulsion system, induction motor and DC motor drives score the highest and these two technologies are slightly more mature than that of permanent magnet brushless and switched reluctance motors. In terms of reliability, the most reliable are the induction motor drives and switched reluctance drives, followed by permanent magnet brushless motor drives. When it comes to the power density, then

permanent magnet brushless motors come out at the top followed by both induction and switched reluctance motors. The DC motor drives could have the lowest power density. In terms of cost factor, the best to be used are the IM followed by the DC and the SR motors. Surprisingly, permanent magnet brushless motors score the least in cost factors when compared with all the others [1], [2], [5] and [6].

**E. Power Electronics**

At present, the IGBT is the most attractive because it possesses high input impedance and the high-speed switching characteristics of the MOSFET together with the good conductivity characteristic of the BJT. In the near future, the MCT would be a good candidate for EV propulsion because it combines high switching speed, high power handling capability, superior dynamic characteristics, and high reliability. In electric vehicles (EV), the state of charge (SOC) of a battery is an important quantity, as it is a measure of the amount of electrical energy stored in the battery. New trends on power electronics converter topologies, such as DC-DC choppers and DC-AC inverters, having significant impact on reliability and performance, and have been introduced for EV applications

[1], [7], [8], [9] and [10].

**F. Control Techniques**

Since the drive systems of EV should be efficient and have to go through frequent start/stop along different operating speeds in different environments, microprocessor based controllers (such as microcontrollers and DSP) together with high performance control systems (such as adaptive and direct torque) have been involved in recent EV technologies [1], [11] and [12].

**G. Others**

Others topics such as human safety issues, efficient operation, reliability, maintenance and cost have gained more attentions for future commercializing of the EVs and competition in marketing to replace the conventional gasoline cars [1] and [5].

**III. THE PROPOSED SETUP**

The proposed drive is designed to work under low voltage/high current. Figure 2 describes the proposed drive system architecture in a block diagram form. The power parts of the drive system are composed from a battery bank followed by a DC to DC chopper for controlling the voltage level; the chopper is then followed by an LC filter to purify the regulated DC voltage. After the LC filter, the power is fed to the DC to AC 3-ph inverter which in turn controls the frequency of the output 3-ph AC voltage supplied to the rewind low voltage high current induction motor. The control parts of the drive are then composed of a switched mode power supply to feed the different control cards with suitable isolated voltage levels from the battery bank, and two different gate drive circuits associated with their control cards for generating suitable gate drive signals for the chopper and the inverter. The inverter is operated with low frequency signals (0-60 Hz, with 180° conduction), which is found more suitable than the high frequency PWM technique for the required higher-current density operating conditions and the available commercial components.

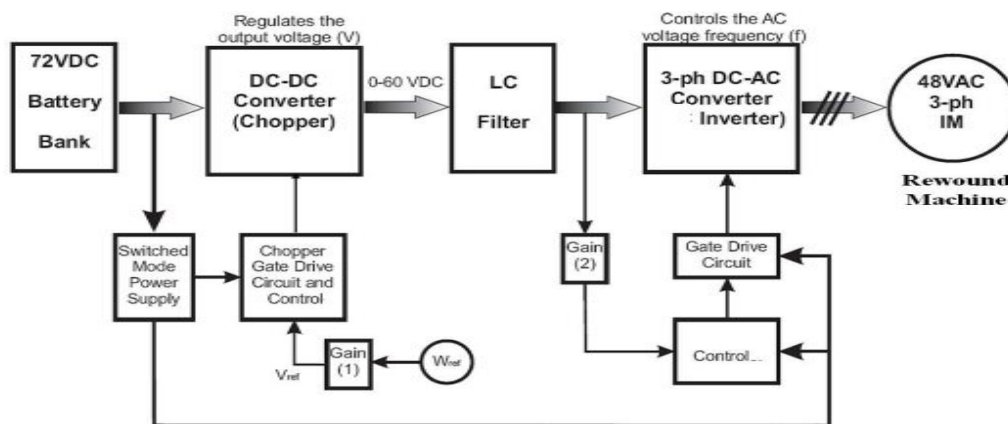

Fig.2. Block diagram of the entire proposed drive system

#### IV. MATLAB MODELING AND SIMULATION RESULTS

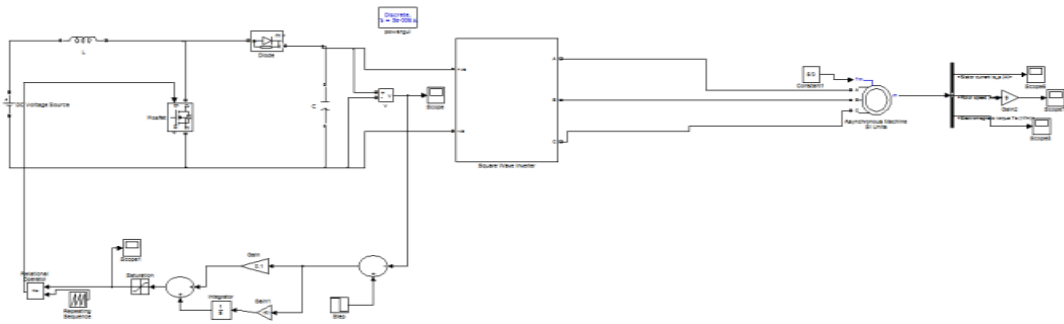

Fig: 4.1 Shows the MATLAB/SIMULATION model of the Electric vehicle with low im.



Fig: 4.2: shows the waveform for the DC voltage.

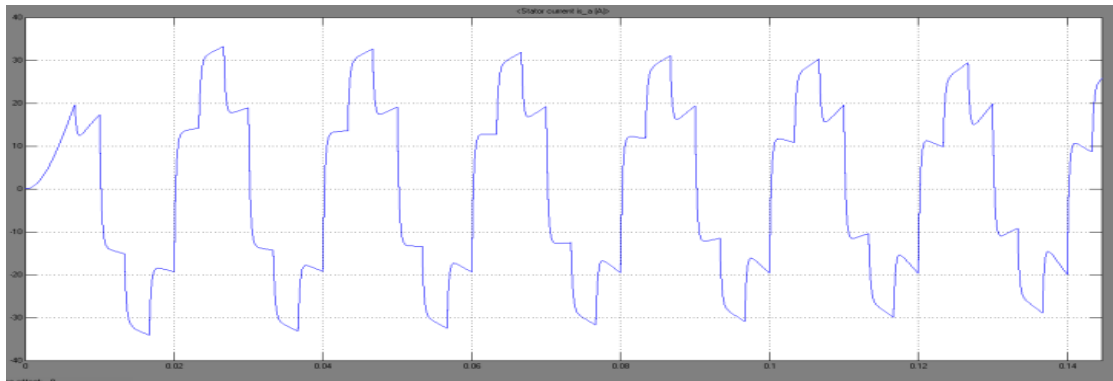

Fig: 4.3: shows the stator current.

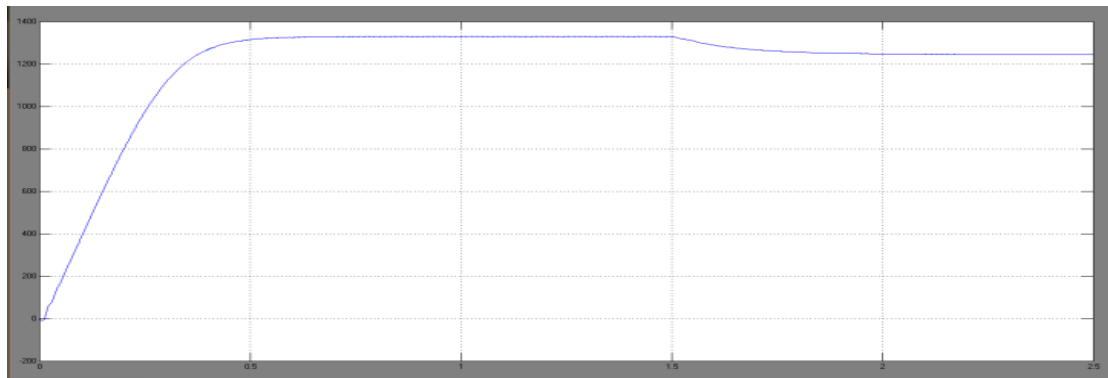

Fig: 4.4: shows the rotor speed.

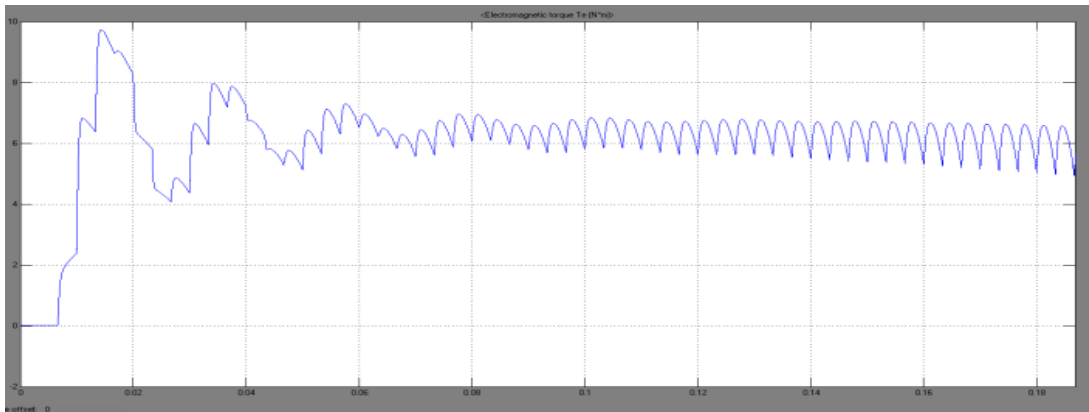

Fig: 4.5: shows the Electromagnetic torque.

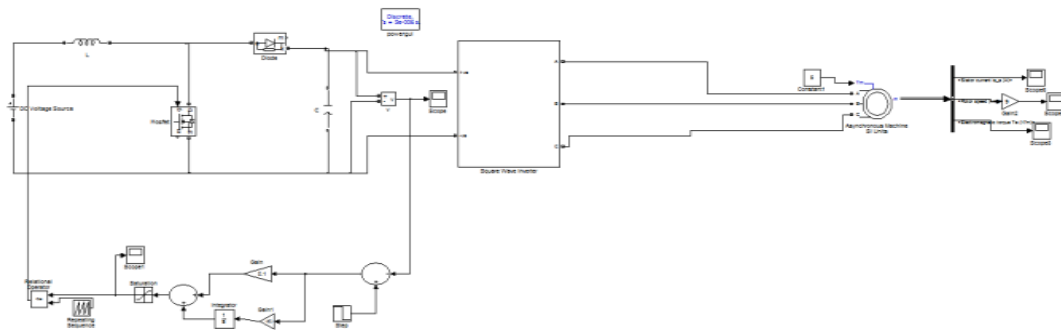

Fig: 4.6 show the MATLAB/SIMULATION model of the Electric vehicle with high im.

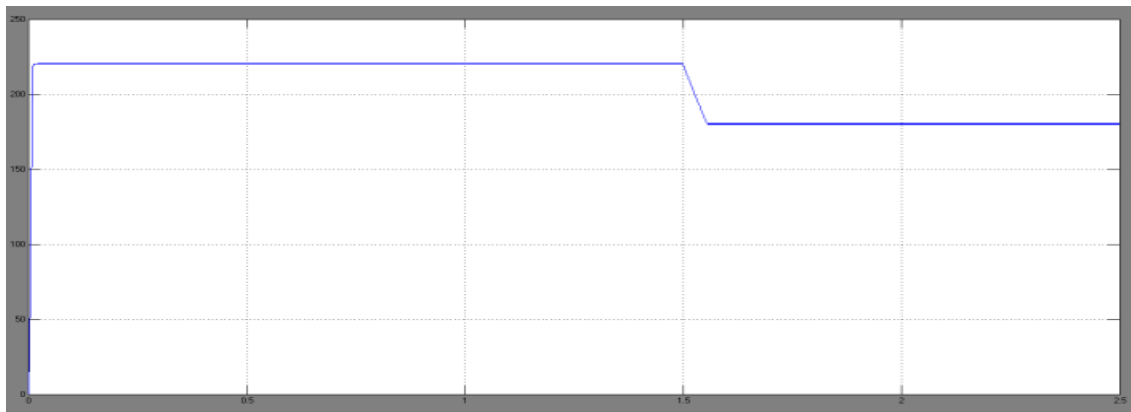

Fig: 4.7: shows the DC voltage.

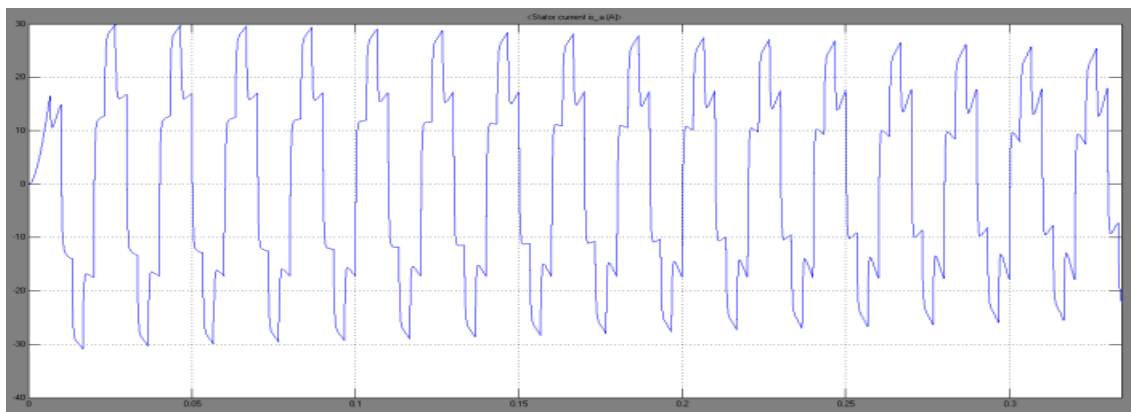

Fig: 4.8: shows the stator current.

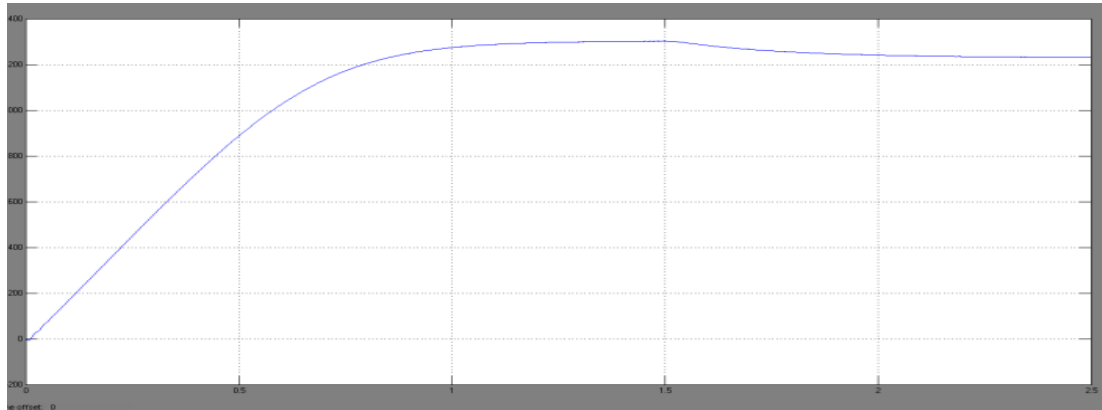

Fig: 4.9: shows the rotor speed.

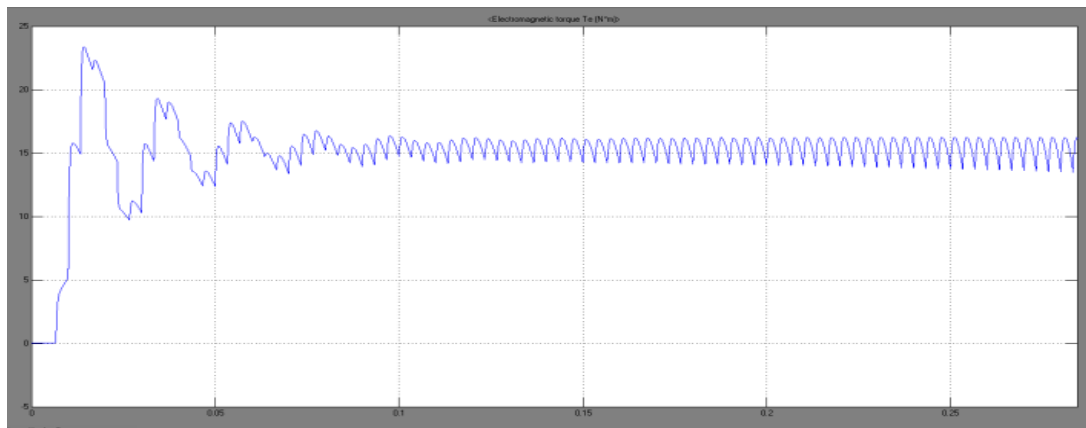

Fig: 4.10: shows the electromagnetic torque.

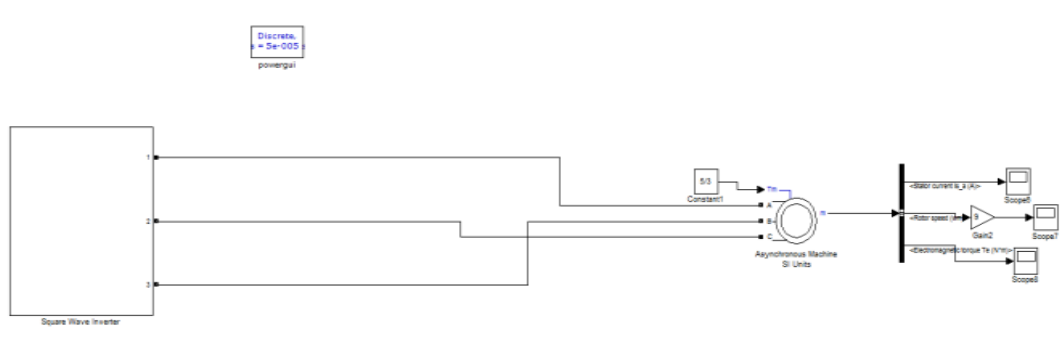

Fig: 4.11 show the circuit for hev.

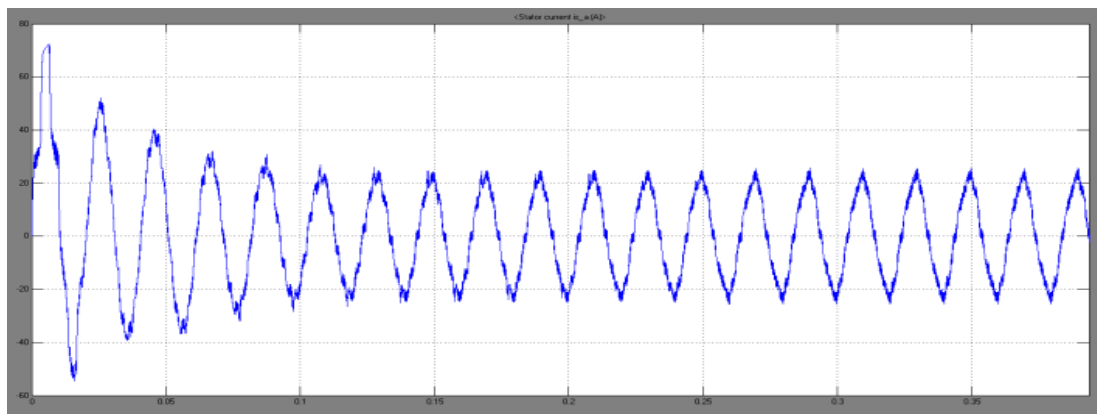

Fig: 4.12 show the stator current.

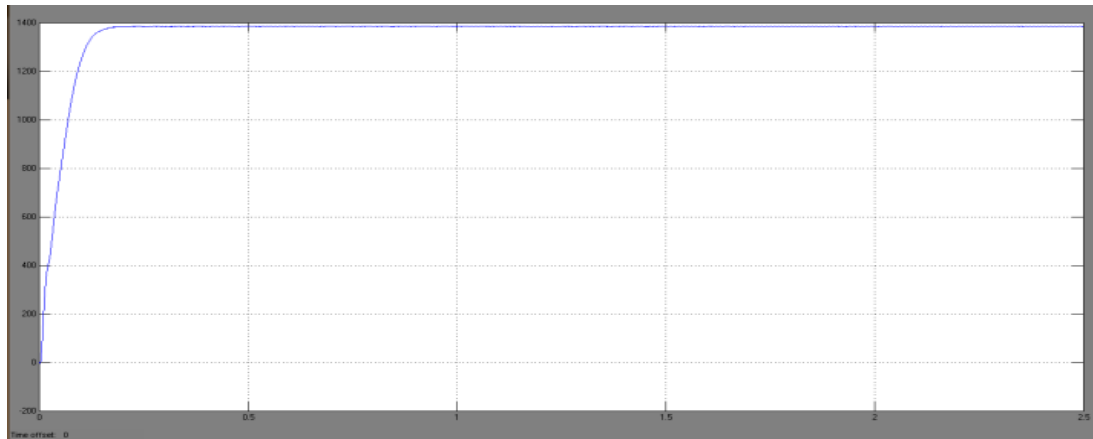

Fig : 4.13: shows the rotor speed.

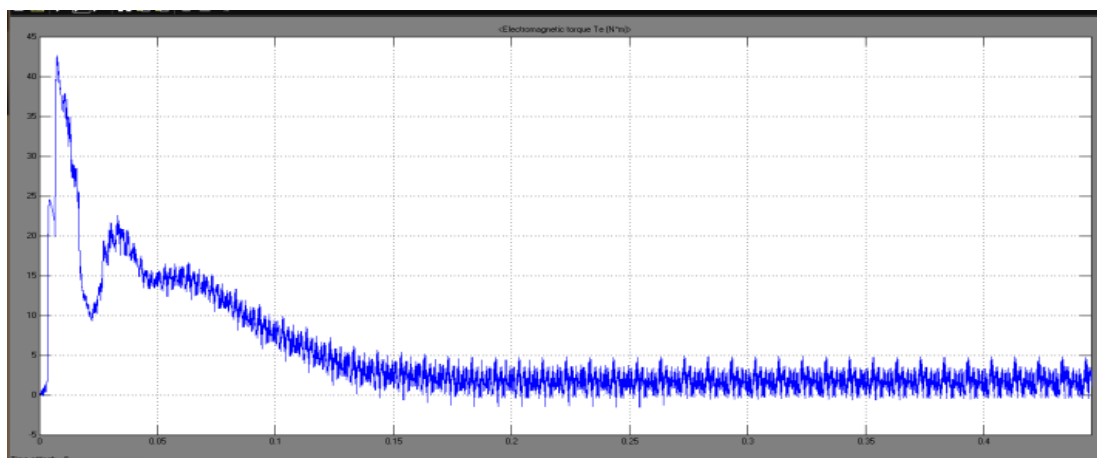

Fig: 4.14: shows the Electromagnetic torque.

#### REFERENCES

- [1] C.C Chan, 'The State of the Art of Electric, Hybrid, and Fuel Cell Vehicles', the IEEE Proceedings, Vol. 95, No. 4, pp. 704 – 718, (2007).
- [2] M. Ehsani, Y. Gao, and J. M. Miller, 'Hybrid Electric Vehicles: Architecture and Motor Drives', Proceedings of the IEEE, Vol. 95, No. 4, pp. 719-728, (2007).
- [3] Z. Amjadi and S.S. Williamson, "Power-Electronics-Based Solutions for Plug-in Hybrid Electric Vehicle Energy Storage and Management Systems" IEEE Transactions on Industrial Electronics, Vol.2, pp. 608–616, (2010).
- [4] B. Balaji, G. S. Ganesh and S. Prasanth, "GSM Emphasized Microwave Powered Electric Vehicle (MicroGSM)", ICECC International Conference, pp.4320-4323, (2011).
- [5] Emadi, J. L. Young and K. Rajashekara, 'Power Electronics and Motor Drives in Electric, Hybrid Electric, and Plug-In Hybrid Electric Vehicles', IEEE Transactions on Industrial Electronics, Vol. 55, No.6, pp. 2237 – 2245, (2008).
- [6] G. Nanda and N. C. Kar, 'A Survey and Comparison of Characteristics of Motor Drives Used in Electric Vehicles', the CCECE '06 Conference, Ottawa, Canada, pp. 808– 814, (2006).
- [7] C.C. Chan and K.T. Chau, 'An Overview of Power Electronics in Electric Vehicles', IEEE Transactions on Industrial Electronics, Vol. 44, No. 1, pp. 3 – 13, (1997).
- [8] S. Kim, 'Nonlinear State of Charge Estimator for Hybrid Electric Vehicle Battery' IEEE Transactions on Power Electronics, Vol. 23, No.4, pp. 2027 – 2034, (2008).



- [9] M. Marz, A. Schletz, B. Eckardt, S. Egelkraut, and H. Rauh, "Power Electronics System Integration for Electric and Hybrid Vehicles", CIPS 6th International Conference, pp.1-10, (2010).
- [10] F. Z. Peng, M. Shen and K. Holland, 'Application of Z-Source Inverter for Traction Drive of Fuel Cell Battery Hybrid Electric Vehicles', IEEE Transactions on Power Electronics, Vol. 22, No.4, pp. 1054 –1061, (2007).
- [11] M. Pahlevaninezhad, J. Drobnik, P.K. Jain,A. Bakhshai, "A Load Adaptive Control Approach for a Zero-Voltage-Switching DC/DC Converter Used for Electric Vehicles", IEEE Transactions on Industrial Electronics, Vol.59, No.2, pp.920-933, (2012).
- [12] Yamashita, T. Tomida and K. Matsuse, 'Performance of the Inverter with the Super Capacitor for Vector Controlled Induction Motor Drives' the IEEE IECON-32nd Annual Conference, pp 946–951, (2006).